

INSTALLATION AND OPERATION MANUAL

Butterfly Valve

Fire Protection Products

FPB-300W | FPB-300W-1012 | FPB-300G | FPB-300G-1012 |
FPB-300GT | FPB-300L | 1352 | 1353

Mechanical Services & HVAC Products

F13A-150 | F13C16 | F13E16 | F13E25 | F1116 | F1125 |
F1216 | F1225 | F11U16 | F17-300
V1116 | V1216 | V13C16

This manual is also available online.



SAFETY PRECAUTIONS



Caution



Read and understand carefully this document prior attempting to install Fivalco® products. Failure to follow these instructions could cause severe injury, product and/or property damage.



Installation, maintenance and replacement of Fivalco® products must be implemented by an experienced, well trained installer. Wear safety glasses, helmet, hand and foot protection during installation.



The owner is responsible for maintaining the system in proper operation condition.



Fivalco shall not be held responsible for any incidents arising from improper installation, operation and maintenance work. The responsibility for this must rest with the installer and user.



Disclaimer

This manual serves as a general guideline and reference to the installers and users. Every effort has been made to ensure the information contained in this manual is accurate at the time of publication. Fivalco Limited assumes no responsibility or liability for any errors and/or misinterpretation of the information. Contact your local vendor, distributor or Fivalco Limited for detail technical data and specification of each model, and if any additional information is required. We reserve the right to alter this manual without notice.

“THE QUALITY GOES IN BEFORE OUR NAME GOES ON”



CONTENTS

Butterfly Valve

1	General	1
2	Unloading & Transportation	1
3	Storage	1
4	Inspection Prior To Installation	2
5	Installation	2
6	Operation Of Valves	5
7	Maintenance	6
8	Warnings	6

BUTTERFLY VALVE

1 GENERAL

Butterfly valves form a significant component of the piping systems, are widely used in various systems to regulate and isolate the medium. Failure of a butterfly valve in such systems, either due to faulty installation or improper maintenance, could result in extensive damage and costly repairs. Problems with or malfunctions of the valves due to faulty installation or improper maintenance may result in extensive and costly operation to effectively correct or eliminate the problem. Many butterfly valve problems and failure can be traced back to improper installation, operation, or maintenance procedures.

Butterfly valves may not be installed and used as anchor points, and should at all times be kept free from stress arising from the system pipeline. Valves should not be installed in applications or for service other than the recommended for that purpose or approved in advance by the manufacture. Valves should not be installed in lines where service pressure will exceed the rated working pressure of the valve.

Butterfly valves should not be used in applications that are exposed to freezing temperature unless sufficient flow is maintained through the valve or other protection is provided to prevent freezing.

2 UNLOADING & TRANSPORTATION

A vital consideration in handling valves should be avoid damaging or scratching the coating protection. Ensure that there are no heavy load and sharp objects are applied to the valves.

All valves should be unloaded carefully. Each valve should be carefully lowered from the truck to the ground; it should not be dropped. In the case of larger valves, forklifts or slings around the body of the valve or under the skids should be used for unloading. Only hoists and slings with adequate load capacity to handle the weight of the valve or valves should be used. Hoists should not be hooked into or chains fastened around the valve operator, tamper switch box or electric actuator. Failure to carefully follow these recommendations is likely to result in damage to the valve.

3 STORAGE

Valves should be stored and delivered with 10° opened so that they are unseated. In order to prevent the entry of foreign material that could cause damage to the seating surface, disc edge or valve interior, do not remove the protection wrapper or unbox the valves until installation. Whenever practical, valves should be stored indoors under dry, cool conditions, away from direct sunlight and corrosive or otherwise chemically active atmosphere. If outside storage is required, means should be provided to protect the operating mechanism from weather elements. During outside storage, valves should be protected from the weather, sunlight, ozone, and foreign materials. In colder climates where valves may be subject to freezing temperatures, it is absolutely essential to remove the water from the valve interior. Failure to do so many results in a cracked valve casting and or deterioration of the resilient seat material.

4 INSPECTION PRIOR TO INSTALLATION

Valves should be inspected at the time of receipt for damage in shipment. The initial inspection should be to verify compliance with specifications, direction of opening, and type of end connections. A visual inspection of the seating surfaces should be performed to detect any damage in shipment or scoring of the seating surfaces. Inspection personnel should look for bent levers, broken handwheels, cracked parts, loose bolt, missing parts and accessories, and any other evidence of mishandling during shipment. Each valve should be operated through one complete opening-and-closing cycle in the position in which it is to be installed.

5 INSTALLATION

At the jobsite prior to installation, each valve should be visually inspected and any foreign material in the interior of the valve should be removed.

Before being installed, the valves need to be cleaned so as to eliminate the dust caused during the transportation and storage. Confirm the type of connection and standard before starting the installation work. Edges of welded mating flanges must be machined for smooth surface so that they may not damage the resilient seat during valve mounting.

Valves can be installed at horizontal or vertical pipe line depending on its application. When being installed, the medium flow direction should be the same as the flowing direction on the valves, if any. Butterfly valves should be installed, if possible, a minimum of 6 pipe diameters from other line elements, i.e., elbows, pumps, valves, etc. Sometimes this is not feasible, but it is important to achieve as much distance as possible. Nevertheless, the installer shall provide sufficient space for valves for easy installation, operation, maintenance, inspection and replacement.

Ensure that the internal pipe diameter has sufficient clearance for valve disc to be fully operated and opened, and does not interfere with the adjacent valves and equipment. Butterfly valves must not be installed with its operator, tamper switch or actuator lower than pipe level on horizontal pipeline. These must be always above the valve body or at least the same level as the valve body.

Always lift the valve by locating holes or by using nylon sling on the neck or the body. Never lift the valve by the operator or actuator mounted on the valve.

During installation, it is essential to ensure an accurate centering between flanges and in a well aligned position so that the stress would not be acting on the valve body. Gaskets are not required on resilient seated valves because they extend to both faces of the valve. Align the pipe-work, and spread the flanges enough to allow the valve body to be easily inserted between the flanges without contacting the pipe flanges. Check that the valve disc has been set to about 10% open so it doesn't become jammed in the fully seated position. Valves shall be mounted on the flanges only after the mating or counter flanges have been welded to the pipe and cooled down to atmospheric temperature. Welding heat may damage the resilient seat or rubber seat of the butterfly valves. Never weld the flanges with valve installed.

Valve installation or in a plant piping system should be supported and aligned to avoid damage to the valves. Valves should not be used to correct the misalignment of piping.

After installation and before pressurization of the valve, the installation should be inspected for adequate tightness to prevent leakage. Proper inspection at this time will minimize the possibility of leaks after pressurization of the piping system.

In order to prevent time lost searching for leaks, it is recommended that the valve excavations are not backfilled until after pressure tests have been made. After installation, it is desirable to test newly installed piping sections, including valves, at some pressure above the system design pressure. It is also recognized that wear or foreign material may damage valve seating surfaces and may cause leakage.

On completion of the installation, valve location, size, make, type, date of installation, number of turns to open, direction of opening, and other information deemed pertinent should be entered on permanent records.

Butterfly valves used for dead end installation, an end cap or blind flange to be bolted with a short pipe in between if it is not connected to a full piping system and/or equipment. Do not install a wafer butterfly valve for dead end installation. Full Lug with tapped holes or double flange butterfly valves shall be used in this application.

Bolt installation for flanged butterfly valves

Installer shall follow the method of installation of butterfly valves as figure 1 below.

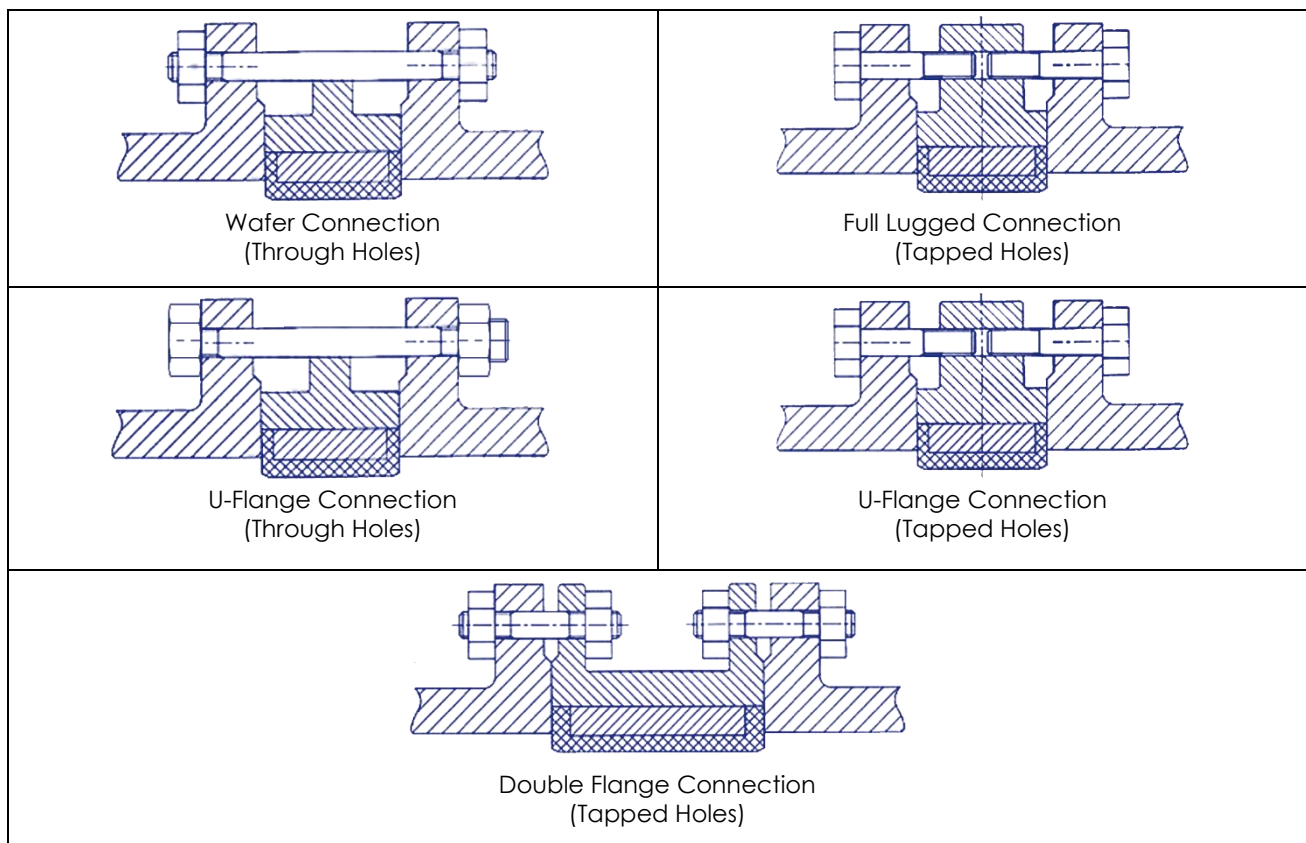

Figure 1: Bolt installation methods for flanged butterfly valves.

Bolts must be tightening in a crosswise pattern (see figure 2). Installer should ensure that the valve flanges are well aligned and an even pressure on the gasket surface is applied.

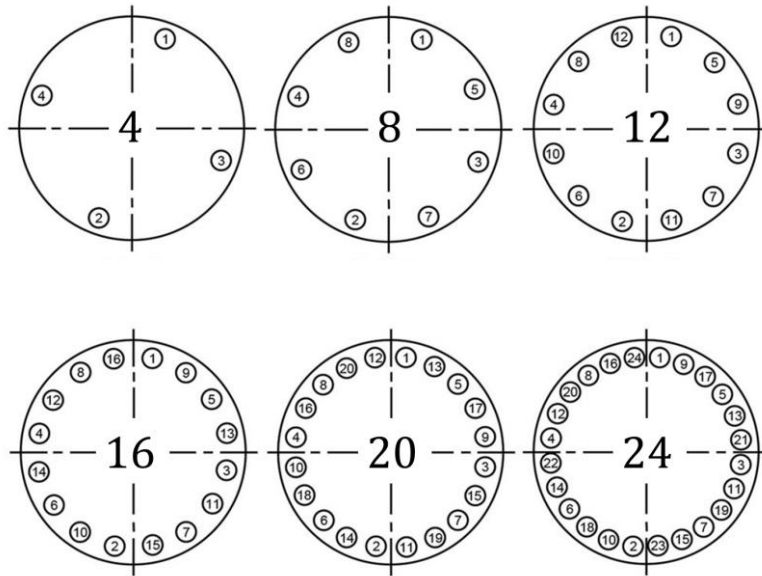

Figure 2: Crosswise pattern for tightening or loosening bolts.

Installation of sprocket handwheel with chain

Loosen the setting screw and remove the bracket. Put the sprocket on the shaft. Align the sprocket pin hole with the shaft pin hole and attach the pin. Install bracket on sprocket. Screw in the setting screw and fix the bracket. Note that the setting screw must not be screwed to the end. Make sure that the bracket can rotate freely. Installation is complete.

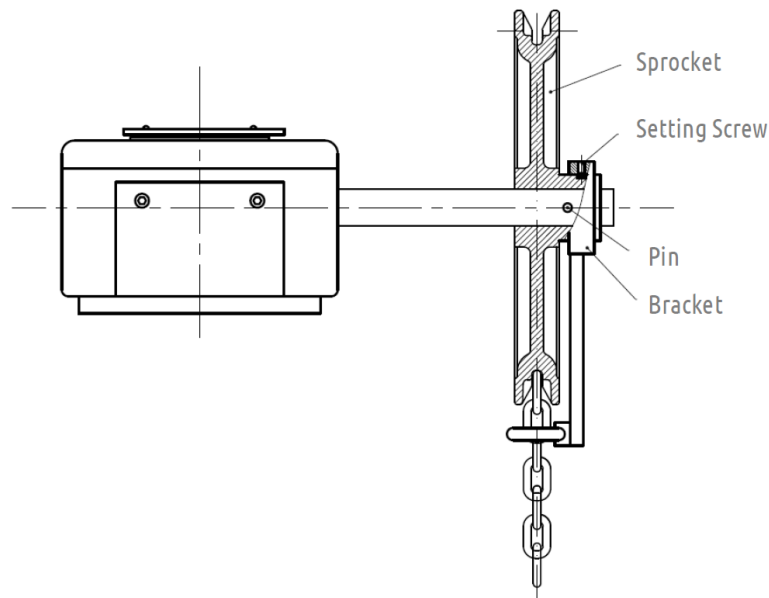

Figure 3: Installation and operation guide for chainwheel gear box.

6 OPERATION OF VALVES

Butterfly valves are quarter turn operation. Turning the valve 90° will fully open or close the valve. Butterfly valves should be slowly turn to close, to prevent water hammering. Valves equipped with manual operators must be operated manually using hand. Excessive force on the operations of valve may damage the valve and/or operator. Using a wrench or tool to clamp on the stem of the butterfly valve and operate is strictly prohibited. To prevent damage or deform of the butterfly valves, it must be operated within the allowable and maximum operating torque (see table 1).

For butterfly valves coupled with electric actuator and sprocket chain hand wheel, they must be operated within its guideline.

Valve Diameter		PN 10		PN 16		PN 25	
		ΔP = 150 (N.m)		ΔP = 200 (N.m)		ΔP = 200 (N.m)	
mm	Inch	WET	DRY	WET	DRY	WET	DRY
DN50	2"	13.9	22.1	15.1	24.2	21.6	34.6
DN65	2.5"	15.4	29.2	17.2	32.7	24.6	46.7
DN80	3"	21.7	41.1	23.1	43.7	33	62.4
DN100	4"	37.1	67.8	39.8	72.8	56.9	104
DN125	5"	57.9	101	61.9	108	88.4	154.3
DN150	6"	93.9	165	102	174	145.7	248.6
DN200	8"	173	297	192	330	274.3	471.4
DN250	10"	286	486	323	549	461.4	784.3
DN300	12"	429	699	490	799	700	1141.4
DN350	14"	550	825	625	969	892.9	1384.3
DN400	16"	755	1133	846	1307	1208.6	1867.1
DN450	18"	1012	1518	1131	1787	1615.7	2552.9
DN500	20"	1350	2025	1431	2288	2044.3	3268.6
DN600	24"	2111	3166	2301	3711	3287.1	5301.4
DN700	28"	3272	4908	4253	6380	6075.7	9114.3
DN750	30"	3767	5650	4897	7345	6995.7	10492.9
DN800	32"	4308	6462	5600	8400	8000	12000
DN900	36"	5257	7886	6834	10251	9762.9	14644.3
DN1000	40"	8926	13389	11603	17405	16575.7	24864.3
DN1050	42"	9024	13536	11731	17596	16758.6	25137.1
DN1100	44"	16800	16800	21840	21840	31200	31200
DN1200	48"	12555	18833	16321	24482	23315.7	34974.3

Table 1: Operating torque for Fivalco Butterfly Valves.

7 MAINTENANCE

If the valve is installed according to our standard procedures, it is maintenance free.

However, for every 4-5 years, we recommend that you carry out a routine check of the valve for leaks around the stem and the flange. All seals will in the course of time be influenced by air and sunshine, frequent and careful checks can reveal leaks.

When the valves being used for some time, the leaking may be happened in the filling area because of the friction caused by the stem moving, you can tighten the connection nut of the filling flange and adjust; it is dangerous to change filling with the pipes full of pressure, so we do not suggest you change the filling when the valves are working. If it is dangerous because of the temperature, high pressure and chemical elements, the filling must not be changed under the pressure situation.

8 WARNINGS

The working pressure, temperature, suitable media of valves must be accord with the regulation of the illumination, or that maybe dangerous.

Prior to any maintenance work that requires disassembly make sure that the pressurized line involved is isolated, depressurized and drained before starting any dissembled. Failure to do so may result in sudden pressure release and subsequent severe injury or death.

If the pressure exceed regulation, the valve maybe leak and the body maybe explode of craze.

If the temperature is too high, the material maybe invalidation and the valve may be broken.

If the media does not accord with the regulation of the illumination, it may rot the body, seat or break the sealing, the body may corrode and craze, the media may be leaked.



WARRANTY STATEMENT

Fivalco's products are designed, engineered and manufactured within its specification of intended use, under the highest quality control possible. Commitment on quality and performance is always at the top of our agenda.

Fivalco warrants that for a period of thirty-six (36) months following delivery, the Fivalco products will perform in accordance with published specifications, and will be free from defects in material or workmanship provided that the products are stored and installed in accordance with recommendations in our catalogues.

Fivalco's obligation shall be to replace any product found to be defective in design, material or workmanship during the warranty period. Fivalco shall not be obligated to refund the purchase price and other liabilities on monetary compensation, nor shall it be obligated to pay for any labor or costs associated with the removal of the defective products or the reinstallation of those products. No warranty coverage will be provided for products that have been altered and / or used for a purpose other than that for which they were designed or installed contrary to Fivalco's guidelines.

Fivalco[®] is Registered Trademark